

LOXONE

Datasheet

Loxone Panel

14.5 x 24 x 4 in

by Shocker Automation

Item No: 500048

About the product:

The Loxone Panel is designed to make the entire installation process efficient. It is designed specifically to conform with US and Canadian certification standards and proudly manufactured with US steel.

- DIN rail space: 3 x 13" for components
- CSA rated for USA & Canada



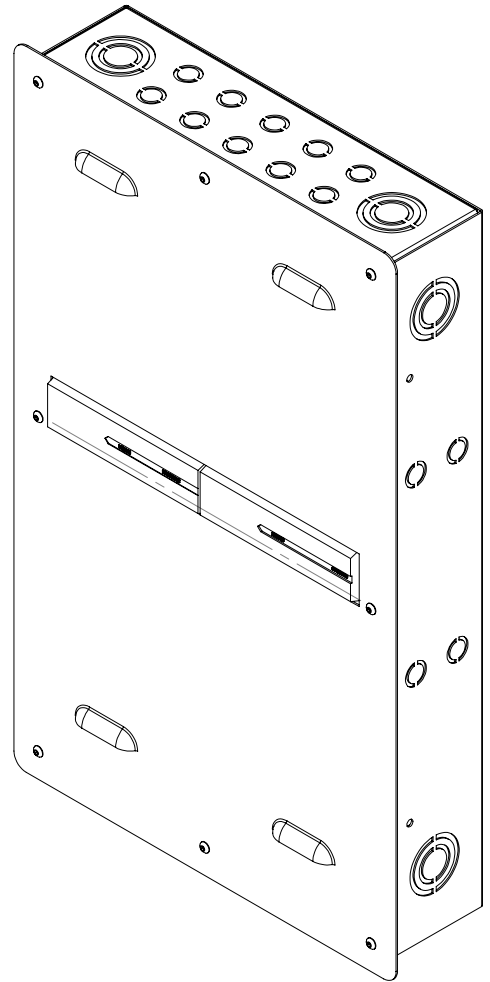
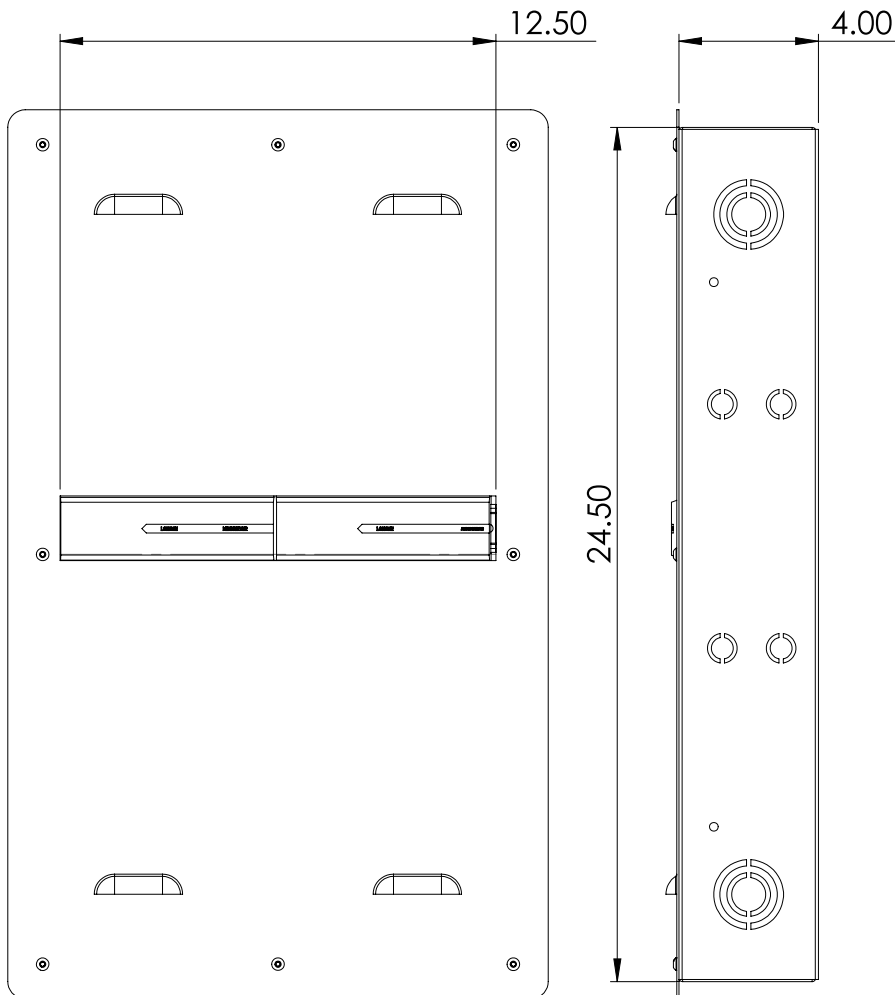
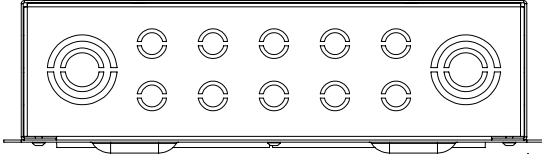

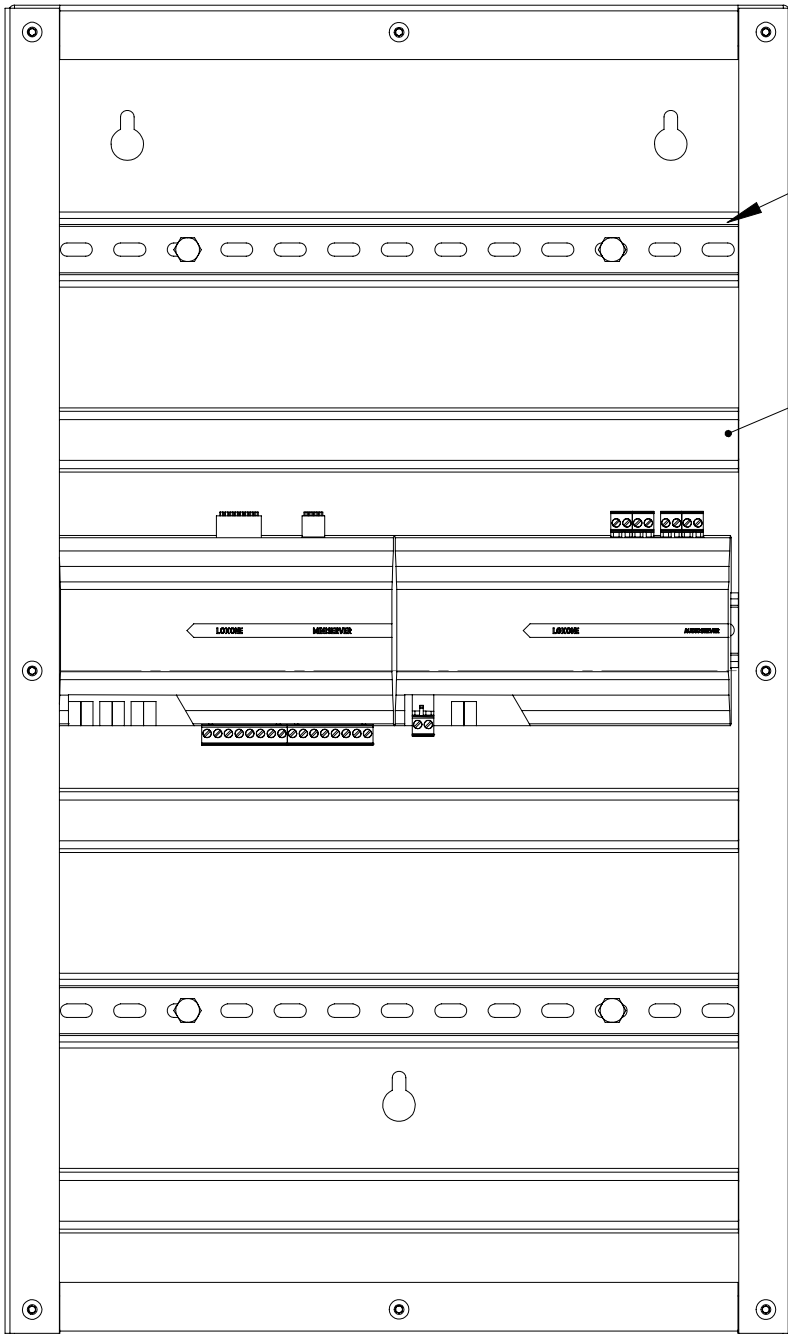

13" Din Rail
Typ. 3

13" 25MM X 60MM
Typ. 3